

# BMA250

## Digital, triaxial acceleration sensor

Bosch Sensortec



**BOSCH**  
Invented for life

### General description

The BMA250 is an advanced, ultra-small, triaxial, low-g acceleration sensor with digital interfaces, aiming for low-power consumer electronics applications.

The BMA250 allows measurement of accelerations in 3 perpendicular axes and thus senses tilt, motion, shock and vibration in cellular phones, handhelds, computer peripherals, man-machine interfaces, virtual reality features and game controllers.

### BMA250 target applications

- ▶ Display profile switching (portrait/landscape, face-up/face-down switching)
- ▶ Flat detection
- ▶ Tap sensing function
- ▶ Menu scrolling
- ▶ Gaming
- ▶ Advanced power management for mobile devices
- ▶ Shock and free-fall detection
- ▶ Step-counting
- ▶ Tilt compensation for electronic compass

### Sensor features

With its size of only 2 mm x 2 mm the BMA250 represents a new generation of digital acceleration sensors. The BMA250 integrates a multitude of features that facilitate its use especially in the area of motion detection applications, such as device orientation detection, gaming, HMI and menu browser control. Featuring a full operation current consumption of only 139  $\mu\text{A}$  the BMA250 is ideally suited for mobile consumer electronic devices. In low-power mode operation the current consumption can be even further reduced by more than one order of magnitude.

The BMA250 is highly configurable in order to give the designer full flexibility when integrating the sensor into his system.

### Sensor operation

The BMA250 supports two modes of operation:

- 1) Streaming data mode: Acceleration data is directly read-out via the sensor's digital interface and computed by a system  $\mu\text{Controller}$ , application processor or a base-band processor.
- 2) Interrupt engine mode: Acceleration data is computed already within the BMA250 by the integrated, programmable interrupt engine. Depending on the programmable settings the integrated interrupt engine of the BMA250 signals the occurrence of certain events via the sensor's two interrupt pins. The corresponding registers of the BMA250 can easily be set and read-out via the digital sensor interface.

BMA250	Technical data
Digital resolution	10 bit
Resolution (in $\pm 2\text{g}$ range)	3.9 mg
Measurement ranges (programmable)	$\pm 2\text{g}$ , $\pm 4\text{g}$ , $\pm 8\text{g}$ , $\pm 16\text{g}$
Sensitivity (calibrated)	$\pm 2\text{g}$ : 256 LSB/g $\pm 4\text{g}$ : 128 LSB/g $\pm 8\text{g}$ : 64 LSB/g $\pm 16\text{g}$ : 16 LSB/g
Zero-g offset (over life-time)	$\pm 80\text{mg}$
Bandwidths (programmable)	1000 Hz ... 8 Hz
Digital inputs/outputs	SPI & I <sup>2</sup> C, 2x interrupt pins
Supply voltage ( $V_{\text{DD}}$ )	1.62 ... 3.6 V
I/O supply voltage ( $V_{\text{DDIO}}$ )	1.2 ... 3.6 V
Temperature range	-40 ... +85°C
Current consumption	
▶ full operation	139 $\mu\text{A}$ (@2 kHz data rate)
▶ low-power mode	7 $\mu\text{A}$ (@40 Hz data rate) 1 $\mu\text{A}$ (@1 Hz data rate)
LGA package	2 x 2 x 0.95 mm <sup>3</sup>
Shock resistance	10.000 g x 200 $\mu\text{s}$

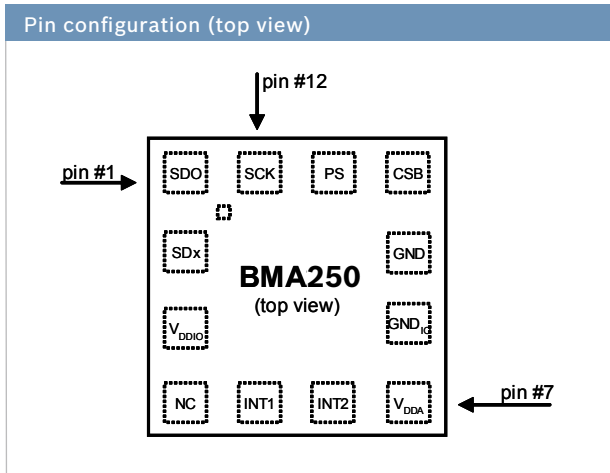

Pin No.	Name	Function
1	SDO	SPI serial data output
2	SDA, SDI, SDO	I <sup>2</sup> C/SPI serial data input/output
3	V <sub>DDIO</sub>	I/O supply voltage
4	N.C.	Not connected
5	INT1	Interrupt output #1
6	INT2	Interrupt output #2
7	V <sub>DD</sub>	Supply voltage
8	GND <sub>IO</sub>	Ground I/O
9	GND	Ground
10	CSB	SPI chip select
11	PS	Protocol select pin (0=SPI,
12	SCK	SCL (I <sup>2</sup> C serial clock) SCK (SPI serial clock)

The BMA250 features I<sup>2</sup>C and SPI (3-wire/4-wire) digital serial interfaces. Sensor parameters, like g-ranges or low-pass filter settings, and also all interrupt engine settings can be easily programmed via the digital interfaces.

### Integrated interrupt engine

One of the key elements of the BMA250 is the enhanced intelligent interrupt engine that gives the hard- and software designer full control. Various motion detection scenarios can be identified by the BMA250 and signaled to the system via two interrupt pins. The interrupt sources can be freely mapped to either of the two interrupt pins.

Following motion detection use case scenarios are supported by the BMA250 interrupt engine:

- ▶ Data-ready (e.g. for processor synchronization)
- ▶ Any-motion (slope) detection (e.g. for wake-up)
- ▶ Tap sensing (e.g. for tap-sensitive UI control)
- ▶ Orientation change recognition (e.g. for portrait/landscape & face-up/face-down switching)
- ▶ Flat detection (e.g. for position sensitive switching)
- ▶ Low-g / high-g detection (e.g. for shock and free-fall detection)

Interrupt parameters (e.g. switching angles and hysteresis settings for orientation change) can be configured by the designer and thus perfectly support the integration of the BMA250 into the user's system environment.

### System compatibility

The BMA250 has been designed for best possible fit into modern mobile consumer electronics devices. Besides the ultra-small footprint and lowest power consumption, the BMA250 has very wide ranges for V<sub>DD</sub> and V<sub>DDIO</sub> supply voltages. An integrated self-test feature facilitates overall system reliability.

#### Headquarters Bosch Sensortec GmbH

Gerhard-Kindler-Strasse 8  
72770 Reutlingen · Germany  
Telephone +49 7121 3535 900  
Fax +49 7121 3535 909  
contact@bosch-sensortec.com  
[www.bosch-sensortec.com](http://www.bosch-sensortec.com)