

# BMA253 Digital, Triaxial Accelerometer

## Shipment Packaging Details



### **BMA253: Shipment packaging details**

Document revision	1.3
Document release date	June 2019
Document number	BST-BMA253-SP000-02
Technical reference codes	0 273 016 001
Notes	Data in this document are subject to change without notice. Product photos and pictures are for illustration purposes only and may differ from the real product's appearance.

## Index of Contents

<b>1. Inner box .....</b>	<b>3</b>
<b>2. Outer box.....</b>	<b>3</b>
2.1 Dimensions.....	4
2.2 Weights .....	4
<b>3. Bar code labeling .....</b>	<b>5</b>
3.1 Label design and fields .....	5
3.2 Label example: BMA253.....	6
<b>4. Reel dimensions.....</b>	<b>7</b>
<b>5. Legal disclaimer .....</b>	<b>8</b>
5.1 Engineering samples .....	8
5.2 Product use .....	8
5.3 Application examples and hints .....	8
<b>6. Document history and modification .....</b>	<b>9</b>

## 1. Inner box



Dimensions of inner box

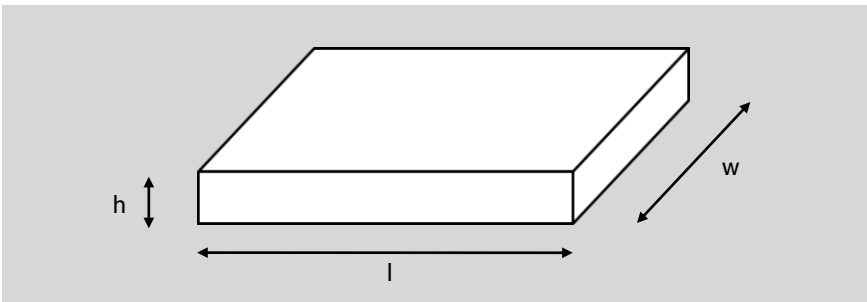

Inner box version	width (w)	length (l)	height (h)
1	~35cm	~35cm	~5cm
2	~34cm	~34cm	~3,5cm

## 2. Outer box



## 2.1 Dimensions

The size of the outer box depends on delivered quantity

Carton Type	Capacity	Dimension
Carton 2	Up to 2 inner boxes	42*42*15 cm
Carton 5	Up to 5 inner boxes	42*42*28 cm
Carton 10	Up to 10 inner boxes	42*42*39 cm
Carton 15	Up to 15 inner boxes	42*42*68 cm

## 2.2 Weights

Weight [kg]* depending on reels in carton:	Carton 2	Carton 5	Carton 10	Carton 15
1 reel	1,4	1,6	1,6	2,0
2 reels	2,1	2,3	2,3	2,7
3 reels	-	3,0	3,0	3,4
4 reels	-	3,7	3,7	4,1
5 reels	-	4,4	4,4	4,8
6 reels	-	-	5,1	5,5
7 reels	-	-	5,8	6,2
8 reels	-	-	6,5	6,9
9 reels	-	-	7,2	7,6
10 reels	-	-	7,9	8,3
11 reels	-	-	-	9,0
12 reels	-	-	-	9,7
13 reels	-	-	-	10,4
14 reels	-	-	-	11,1
15 reels	-	-	-	11,8

\*Note: Weights may vary slightly depending on product and inner box

### 3. Bar code labeling

#### 3.1 Label design and fields

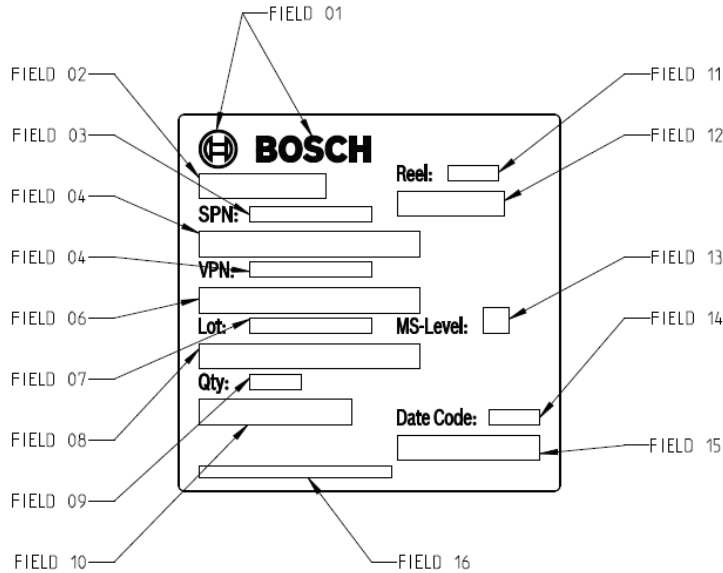

The dimension of the bar code label is approximately 72mm x 73mm (hwx).

Field	Description	Format
01	Bosch Symbol	
02	Part description	Text
03	Sales Part number (SPN)	Text
04		Barcode
05	Bosch internal number (VPN)	Text
06		Barcode
07	Lot Number	Text
08		Barcode
09	Quantity	Text
10		Barcode
11	Reel number	Text
12		Barcode
13	MS-Level	Text
14	Date Code	Text (yy/ww)
15		Barcode
16	CoO / Made in*	Text

\* except for Taiwan: only Made in Taiwan, no CoO

Notes:

- ▶ The ink on the label is lead-free.
- ▶ Heat-pressure method for label is used.
- ▶ Bar code label is on reel and the inner box

3.2 Label example: BMA253



## 4. Reel dimensions

- ▶ The reel size is 13"
- ▶ 1 reel contains 10,000 parts

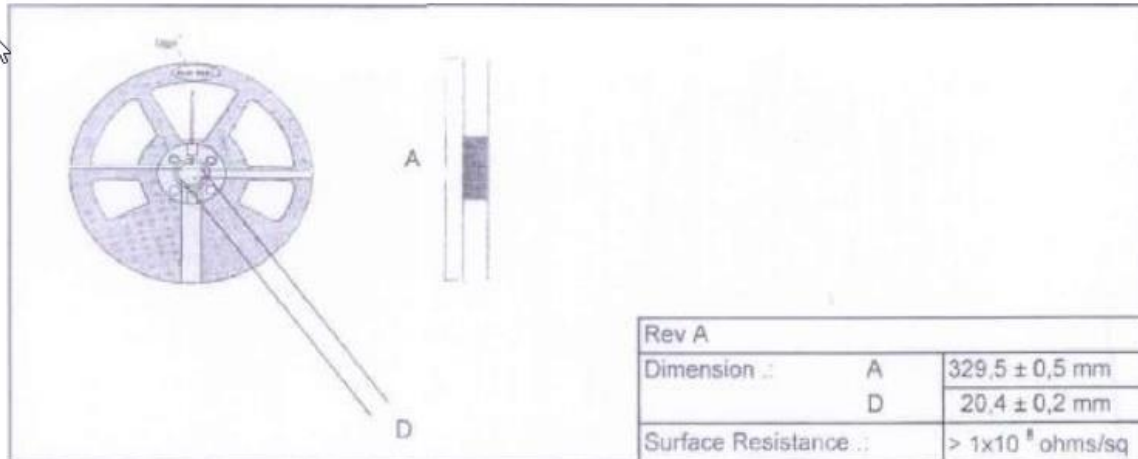

## 5. Legal disclaimer

### 5.1 Engineering samples

Engineering Samples are marked with an asterisk (\*) or (e) or (E). Samples may vary from the valid technical specifications of the product series contained in this data sheet. They are therefore not intended or fit for resale to third parties or for use in end products. Their sole purpose is internal client testing. The testing of an engineering sample may in no way replace the testing of a product series. Bosch Sensortec assumes no liability for the use of engineering samples. The Purchaser shall indemnify Bosch Sensortec from all claims arising from the use of engineering samples.

### 5.2 Product use

Bosch Sensortec products are developed for the consumer goods industry. They may only be used within the parameters of this product data sheet. They are not fit for use in life-sustaining or safety-critical systems. Safety-critical systems are those for which a malfunction is expected to lead to bodily harm, death or severe property damage. In addition, they shall not be used directly or indirectly for military purposes (including but not limited to nuclear, chemical or biological proliferation of weapons or development of missile technology), nuclear power, deep sea or space applications (including but not limited to satellite technology).

The resale and/or use of Bosch Sensortec products are at the purchaser's own risk and his own responsibility. The examination of fitness for the intended use is the sole responsibility of the purchaser.

The purchaser shall indemnify Bosch Sensortec from all third party claims arising from any product use not covered by the parameters of this product data sheet or not approved by Bosch Sensortec and reimburse Bosch Sensortec for all costs in connection with such claims.

The purchaser accepts the responsibility to monitor the market for the purchased products, particularly with regard to product safety, and to inform Bosch Sensortec without delay of all safety-critical incidents.

### 5.3 Application examples and hints

With respect to any examples or hints given herein, any typical values stated herein and/or any information regarding the application of the device, Bosch Sensortec hereby disclaims any and all warranties and liabilities of any kind, including without limitation warranties of non-infringement of intellectual property rights or copyrights of any third party. The information given in this document shall in no event be regarded as a guarantee of conditions or characteristics. They are provided for illustrative purposes only and no evaluation regarding infringement of intellectual property rights or copyrights or regarding functionality, performance or error has been made.



## 6. Document history and modification

Rev. No	Chapter	Description of modification/changes	Date
1.0	All	Document creation	21-Aug-2015
1.1	1	Inner box size changed	18-May-2018
1.2	1 2	Weight of inner box Size and weight of outer box	16-Aug-2018
1.3	1 3 5	Inner box sizes Label design change (PCN: BST-VSP-PN000-00) Disclaimer Update	19-June-2019

**Bosch Sensortec GmbH**  
Gerhard-Kindler-Straße 9  
72770 Reutlingen / Germany

[contact@bosch-sensortec.com](mailto:contact@bosch-sensortec.com)  
[www.bosch-sensortec.com](http://www.bosch-sensortec.com)

Modifications reserved  
Specifications subject to change without notice  
Document number: BST-BMA253-SP000-02  
Revision\_1.3