

# BME280 Combined humidity and pressure sensor

## Shipment and Packaging Details



### BME280 - Shipment and Packaging Details

Document revision	1.2
Document release date	February 2025, valid from July 2025 onwards
Document number	BST-BME280-SP000-03
Sales Part Number(s)	0 273 141 185
Notes	Data and descriptions in this document are subject to change without notice. Product photos and pictures are for illustration purposes only and may differ from the real product appearance. The technical details and legal disclaimer of the respective product data sheet apply.

# Table of Contents

<b>1 Inner box</b>	<b>3</b>
<b>2 Outer Box</b>	<b>4</b>
2.1 Dimensions	4
2.2 Weights	5
<b>3 Bar Code labeling</b>	<b>6</b>
3.1 Label design and fields	6
3.2 Label example: BMA253	7
<b>4 Reel dimensions</b>	<b>7</b>
<b>5 Document history and modification</b>	<b>8</b>

# 1 Inner box



Picture 1: Open box with reel

Table 1: Dimension of inner box



## 2 Outer Box



### 2.1 Dimensions

The size of the outer box depends on delivered quantity.

Table 2: Dimension and capacity of outer boxes

Carton Type	Capacity	Dimension
Carton 2	Up to 3 inner boxes	42*42*15 cm
Carton 5	Up to 6 inner boxes	42*42*28 cm
Carton 10	Up to 11 inner boxes	42*42*39 cm
Carton 15	Up to 15 inner boxes	42*42*68 cm

## 2.2 Weights

Table 3: Weights

Weight [kg]* depending on reels in carton:	Carton 2	Carton 5	Carton 10	Carton 15
1 reel	1.4	1.5	1.5	2.3
2 reels	1.9	2.0	2.1	2.8
3 reels	2.5	2.6	2.6	3.4
4 reels	-	3.1	3.2	3.9
5 reels	-	3.7	3.7	4.5
6 reels	-	4.2	4.3	5
7 reels	-	-	4.8	5.6
8 reels	-	-	5.4	6.1
9 reels	-	-	5.9	6.7
10 reels	-	-	6.5	7.2
11 reels	-	-	7.0	7.8
12 reels	-	-	-	8.3
13 reels	-	-	-	8.9
14 reels	-	-	-	9.4
15 reels	-	-	-	10.0

\* Weights may vary slightly depending on product and inner box

### 3 Bar Code labeling

#### 3.1 Label design and fields

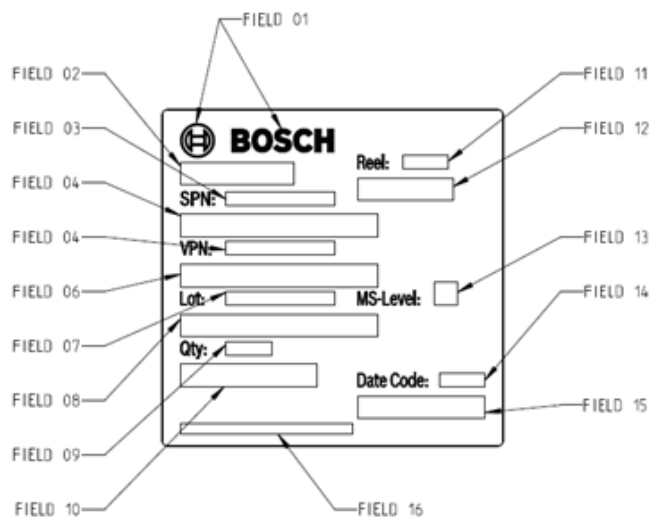

The dimension of the bar code label is approximately 72mm x 73mm (h x w).

Notes:

- The ink on the label is lead-free.
- Heat-pressure method for label is used.
- Bar code label is on reel and the inner box

Table 4: Label fields description

Field	Description	Format
01	Bosch Symbol	Image
02	Part description	Text
03	Sales Part Number (SPN)	Text
04	Bosch internal number (VPN)	Barcode
05	Lot Number	Text
06	Quantity	Barcode
07	Reel number	Text
08	MS-Level	Barcode
09	Date Code	Text (yy/ww)
10	Quantity	Text
11	Reel number	Barcode
12	MS-Level	Text
13	Date Code	Text (yy/ww)
14	Quantity	Barcode
15	CoO / Made in*	Text
16	CoO / Made in*	Text

\* except for Taiwan: only Made in Taiwan, no CoO

### 3.2 Label example: BMA253



## 4 Reel dimensions

- The reel is 13"
- 1 reel contains 10,000 parts

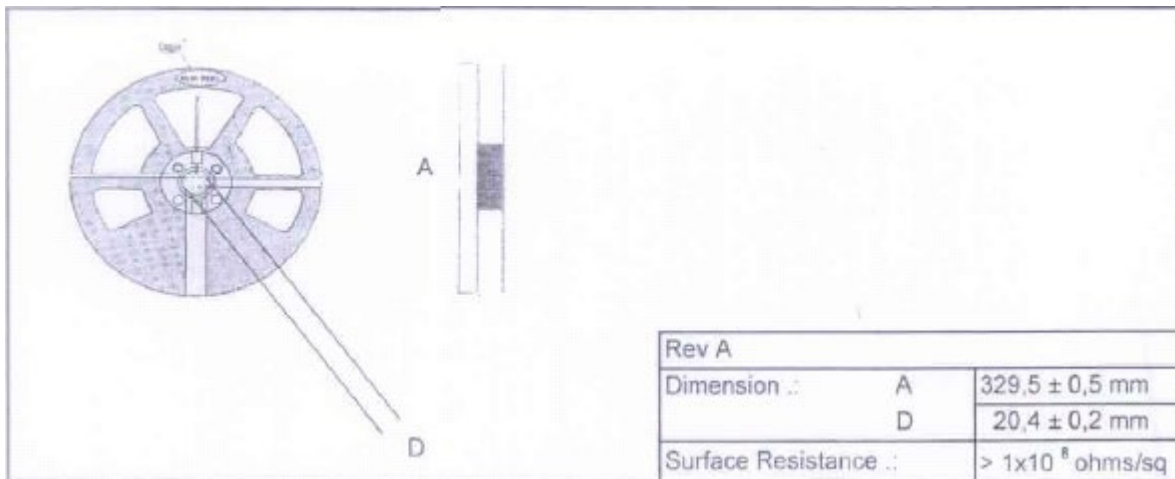

## 5 Document history and modification

Rev. No	Chapter	Description of modification/changes	Date
1.0	all	Initial release	March 2014
1.1	all	New template	May 2018
1.2	All	Minor changes to overall design	February 2025
	1	New inner box dimensions	
	2	New capacities and weights	
	3,4	Label information updated	
	-	Disclaimer removed and a reference added to the note in the first page	



**Bosch Sensortec GmbH**

Gerhard-Kindler-Straße 9  
72770 Reutlingen / Germany

[contact@bosch-sensortec.com](mailto:contact@bosch-sensortec.com)  
[www.bosch-sensortec.com](http://www.bosch-sensortec.com)

Modifications reserved

Document number: BST-BME280-SP000-03