

### NINA\_B302

02\_NINA\_B302.SchDoc

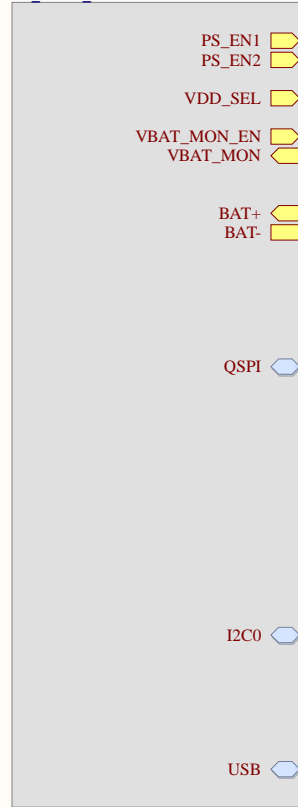

### Power

03\_Power.SchDoc

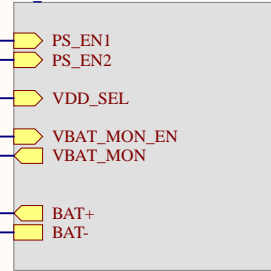

### Flash Memory

04\_FLASH MEMORY.SchDoc



### Temperature\_sensor

06\_Temperature\_sensor.SchDoc

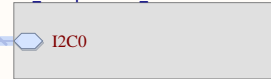

### USB-con

07\_USB-Con.SchDoc

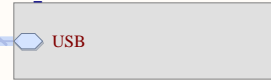

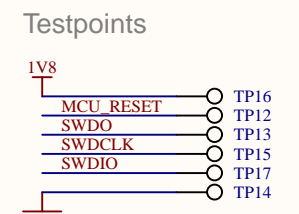
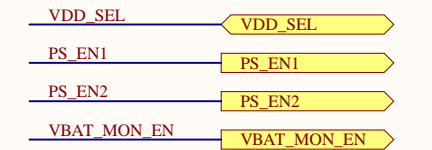
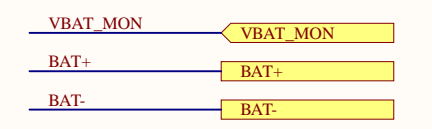
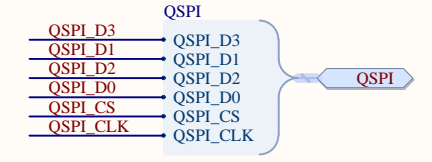
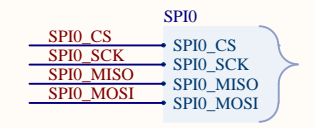
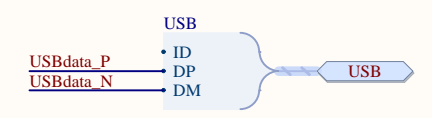
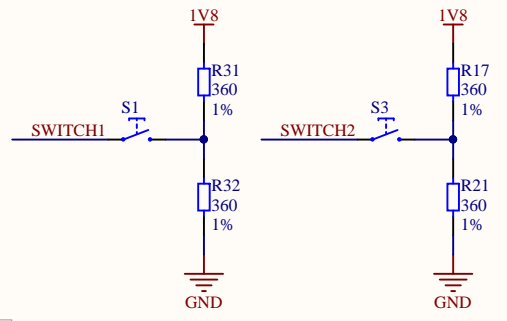
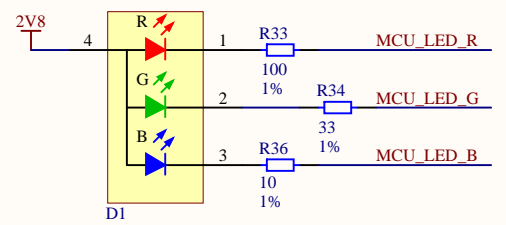
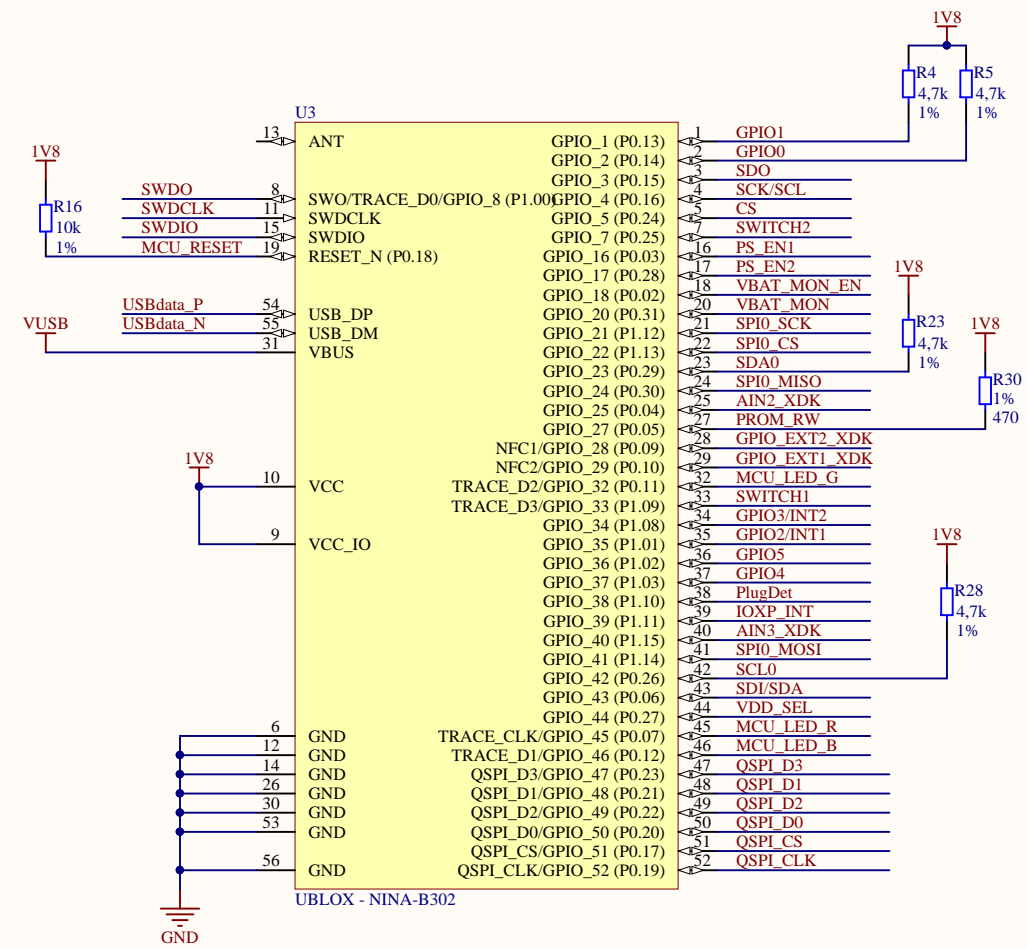
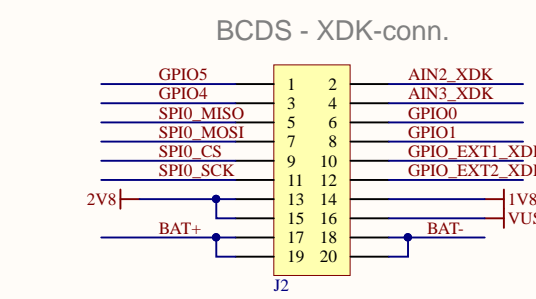
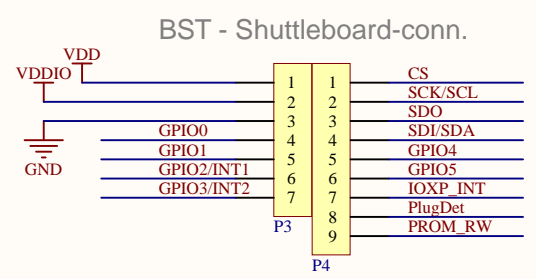
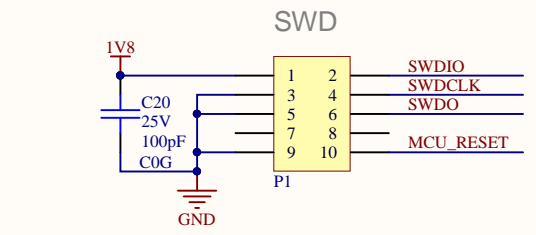

<-- esd protection diodes for "BST - Shuttleboard-conn." -->

<-- esd protection diodes for "BCDS - XDK-conn." -->

